

THIS DRAWING IS UNPUBLISHED. RELEASED FOR PUBLICATION, 19
 © COPYRIGHT 19 BY AMP INCORPORATED. ALL INTERNATIONAL RIGHTS RESERVED.

LOC	DIST	P	F	ZONE	LTR	DESCRIPTION	DATE	APPD
AF	50				AG	REV PER 0710-0302-95	7/13/95	JR/JG

1 CONTINUOUS STRIP ON REELS.

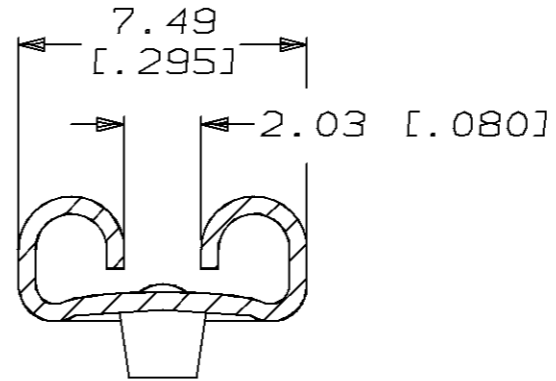
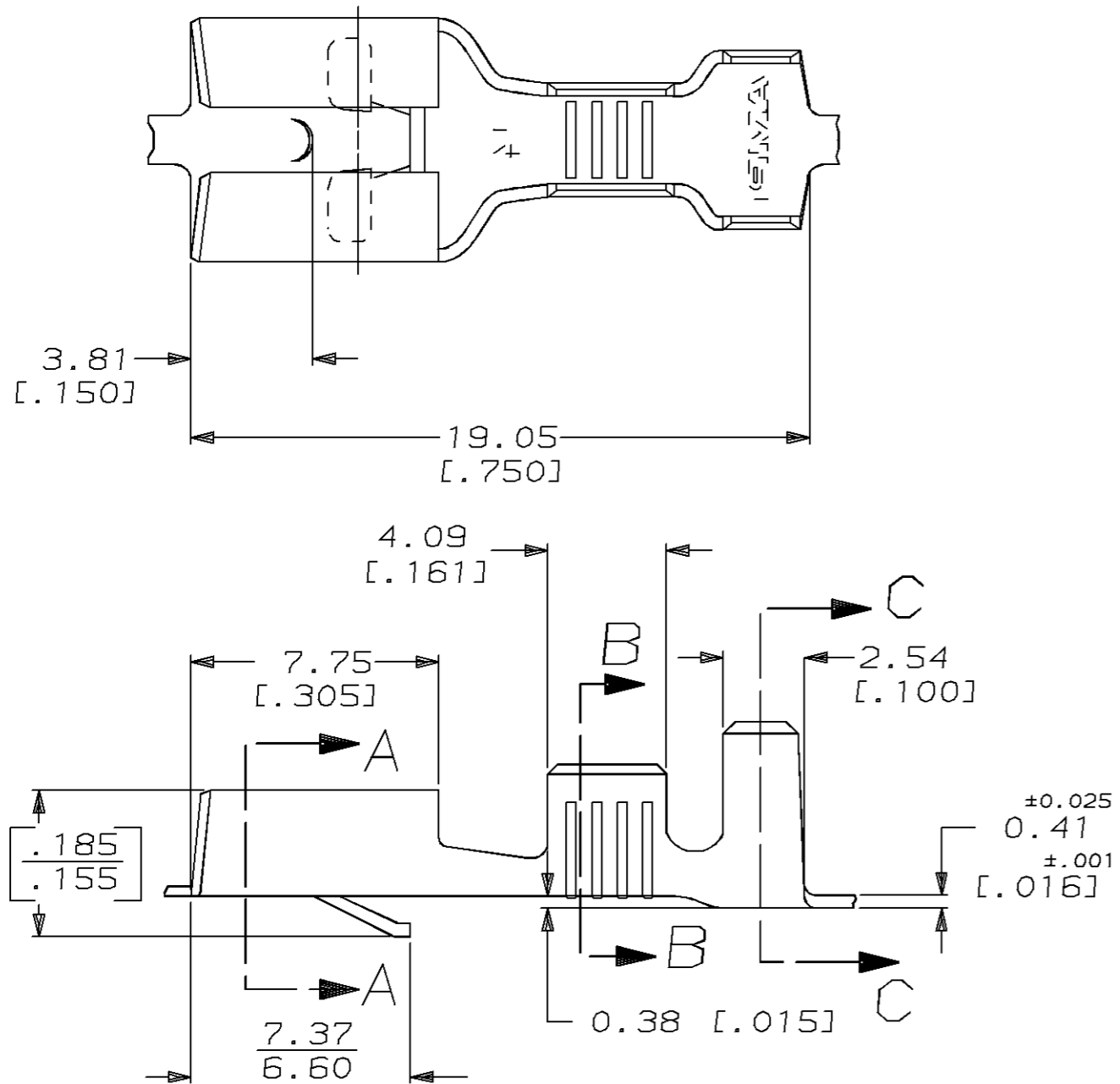

SECTION A-A

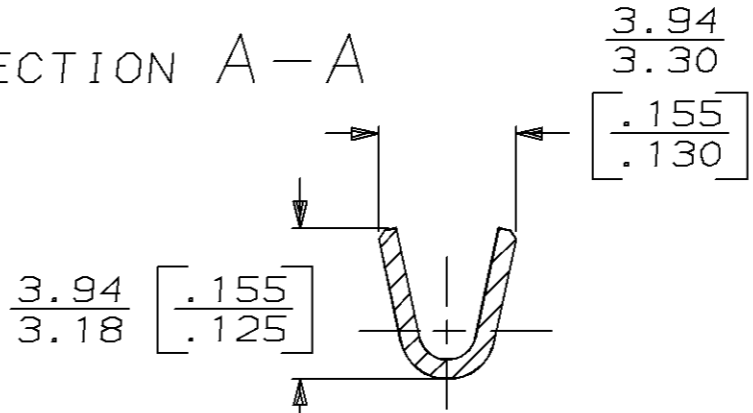

SECTION B-B

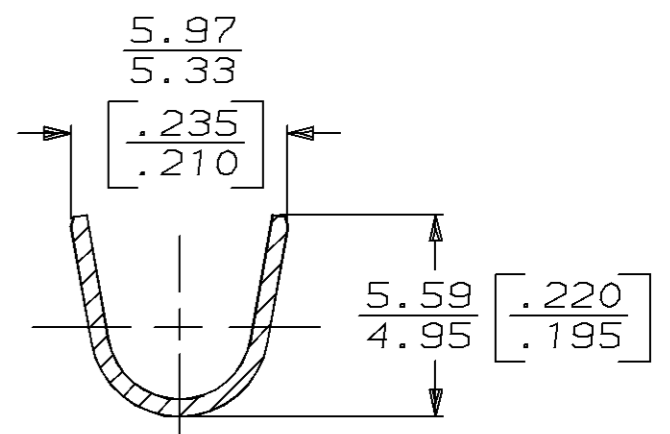

SECTION C-C

THIS DRAWING IS A CONTROLLED DOCUMENT FOR AMP INCORPORATED. IT IS SUBJECT TO CHANGE AND THE CONTROLLING ENGINEERING ORGANIZATION SHOULD BE CONTACTED FOR THE LATEST REVISION.

2.54-4.32 DIA [.100-.170] DIA	0.8-2.0mm ² [18-14] AWG	0.81 [.032]	60634-1
INSUL RANGE	WIRE SIZE	MATING TAB THK ±0.025 [.001]	PART NO
DO NOT SCALE PRINT. UNLESS SPECIFIED DIMENSIONS IN mm [INCHES] TOLERANCES ON: 2 PLC DEC ± 0.25 [.010] 3 PLC DEC ± - ANGLES ± -	DR 8/19/93 JR RUTH CHK 8/19/93 MS FEHER APPD 8/19/93 J GILLESPIE APPD 8/19/93 R REINER PRODUCT SPEC -	AMP AMP Incorporated Harrisburg, PA 17105-3608	
MATERIAL 4M BRASS	FINISH -	NAME RECEPTACLE, FASTIN-FASTON, 6.35 [.250] SERIES	
	APPLICATION SPEC 114-2025	SIZE B	CAGE CODE 00779
	WEIGHT -	DRAWING NO C-60634	SHEET 1 OF 1
		SCALE 5:1	